

MARCO[®]

MARINE TECH

FISCHIO PNEUMATICO OMOLOGATO
(Trombe per imbarcazioni da 12m a 20m)

APPROVED PNEUMATIC WHISTLE

(Marine Horns for vessels between 12m to 20m in length)

AVVERTENZE D'USO
INSTRUCTIONS FOR USE

150 002 12 PW2-BC - 12V

150 002 13 PW2-BC - 24V

150 003 12 PW2-BB - 12V

150 003 13 PW2-BB - 24V

150 006 12 PW2-BN - 12V

150 006 13 PW2-BN - 24V

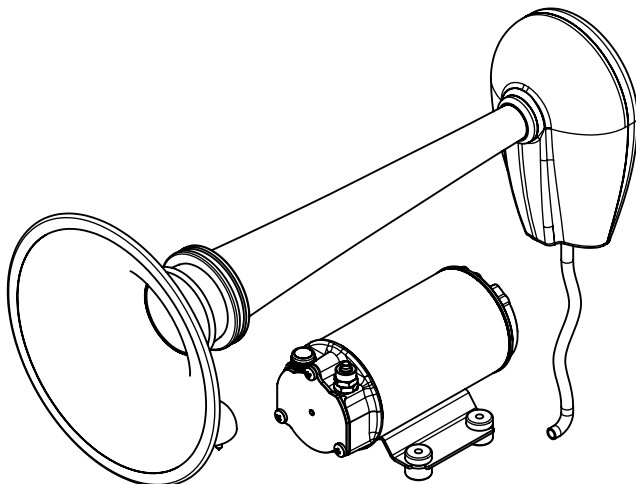

CE

30/08/23 Rev.09

A DESCRIZIONE DEL DISPOSITIVO

Avvisatore sonoro omologato completo di tromba \varnothing 200mm, compressore elettrico e accessori di montaggio. Omologazione RINA, LLOYD'S REGISTER MCA e BUREAU VERITAS in accordo alle norme internazionali COLREG 1972 IMO classe IV, NMMA ABYC A-23.

B DATI TECNICI

CODICE	TIPO	VOLT	FUSIBILE	dB (1/3 OCT.)(1m)	Hz	PESO	P.ZI x CART.
150 002 12	PW2-BC	12	25 A	>120	315	4,9 kg	1
150 002 13		24	20 A				
150 003 12	PW2-BB	12	25 A				
150 003 13		24	20 A				
150 006 12	PW2 -BN	12	25 A				
150 003 13		24	20 A				

C CONDIZIONI AMBIENTALI

TEMPERATURA : min. -25 °C / max. +60 °C **UMIDITA' RELATIVA** : max. 90 %

Lo stoccaggio deve avvenire in luogo asciutto.

D ALIMENTAZIONE ELETTRICA

Il dispositivo deve essere alimentato da un generatore di corrente continua (batteria o alimentatore) protetto da fusibile.

E CICLO DI LAVORO

Il fischio è progettato per un uso discontinuo.

Le temperature limite indicate si applicano ai componenti del dispositivo e devono essere rispettate per evitare possibili danneggiamenti o malfunzionamenti.

F APPLICAZIONI

Dispositivo per segnalazione acustica.

G MOVIMENTAZIONE E TRASPORTO

Peso e dimensioni del dispositivo non richiedono per la movimentazione l'uso di mezzi di sollevamento particolari. In caso di movimentazione manuale utilizzare i normali dispositivi di prevenzione individuale (scarpe di sicurezza con puntale, etc...). Prima della spedizione il dispositivo viene accuratamente imballato.

Controllare l'imballo al ricevimento ed immagazzinare in luogo asciutto.

INSTALLAZIONE

H

Si raccomanda l'uso secondo le disposizioni vigenti in termini di sicurezza e le precauzioni di seguito riportate.

SMALTIMENTO IMBALLO

H-1

Si invita l'utente ad effettuare un'adeguata raccolta differenziata in modo da favorire il riciclo dei materiali di cui è composto l'imballo; smaltimento con CER 15.01.01/02.

CONTROLLI PRELIMINARI

H-2

Controllare che il fischio non abbia subito danni durante il trasporto o lo stoccaggio. Pulire con cura la bocca di mandata rimuovendo eventuale polvere o materiale d'imballo residuo. Verificare che l'alimentazione elettrica disponibile corrisponda a quella richiesta dal dispositivo.

POSIZIONAMENTO DEL DISPOSITIVO

H-3

Il compressore elettrico può essere installato in qualsiasi posizione utilizzando viti adeguate e gli antivibranti a corredo.

COLLEGAMENTO DELLE TUBAZIONI

H-4

Evitare strozzature del tubo in mandata in modo da ottimizzare le prestazioni del fischio.

INSTALLAZIONE DEL DISPOSITIVO

H-5

Il compressore va installato con collegamento elettrico dotato di protezione a fusibile dimensionato come indicato sull'etichetta del motore.

IL MANCATO UTILIZZO DEL FUSIBILE FA DECADERE LA GARANZIA

Montare sempre gli antivibranti in gomma forniti nel kit del compressore. Il loro utilizzo consente una riduzione consistente della rumorosità e attenua le vibrazioni generate. Il dimensionamento dei cavi di alimentazione del compressore va effettuato in funzione della distanza del compressore dalla batteria generatore.

Sezione dei cavi:

per collegamenti alla batteria fino a 5 metri: 4,0 mm² per 12V - 2,5 mm² per 24V

L'utilizzo di cavi sottodimensionati provoca il surriscaldamento degli stessi con reale pericolo di incendio. In tutti i casi si verifica caduta di tensione ai capi del compressore con relativa perdita di prestazioni.

Le prestazioni indicate sull'etichetta del compressore si ottengono utilizzando un tubo di diametro interno di 6 mm. Tubi di diametro inferiore provocano un maggior assorbimento di corrente con conseguente rischio di surriscaldamento del motore.

ATTENZIONE: è responsabilità dell'installatore eseguire una installazione a norma e con corretto dimensionamento del circuito. È da considerarsi il grado di rischio dell'ambiente in cui viene installato il dispositivo.

1. **Montare la tromba inclinandola leggermente verso il basso (5°) per evitare il ristagno d'acqua all'interno del cono.**
2. Collegare il gruppo altoparlante al compressore attraverso il tubo rilsan ed utilizzando gli accessori del kit come da schema allegato.
3. Fissare il compressore ad un piano con delle viti M5. Utilizzare gli appositi antivibranti in gomma in modo da evitare le vibrazioni durante il funzionamento.
4. Collegare il pulsante di azionamento in serie al cavo rosso.
5. Collegare l'estremo del cavo rosso al polo positivo della batteria (+) e l'estremo del cavo nero al polo negativo della batteria (-).

H-6

SEQUENZA DI MONTAGGIO

1. Forare il piano di appoggio (14) del fischio utilizzando il tappeto in gomma (11) come dima;
2. Svitare le tre viti M5x25 (1) e la vite M5x30 (2);
3. Togliere il guscio posteriore (3);
4. Estrarre le tre molle (5);
5. Sfilare delicatamente la cartuccia (6) infilando un cacciavite tra il guscio che la contiene (8) e la cartuccia stessa, facendo leva nel punto "C" (Tab.1);
6. Appoggiare il tappeto in gomma (11) sul piano di appoggio (14);
7. Appoggiare il guscio anteriore (8) sul tappeto in gomma (11);
8. Fissare il guscio anteriore completo di tromba (8) sul piano di appoggio (14) con le viti M5 (9) complete di rondelle elastiche (10) e bloccarlo tramite i dadi autobloccanti (13) preceduti dalle rondelle (12);
9. Infilare dal basso il tubo rilsan nell' apposito foro (B) e inserirlo nel raccordo rapido (A).
10. Centrare la cartuccia (6) sul tubo centrale del guscio anteriore (8). Accertarsi che il tubo monti l'OR (7) in testa, che la cartuccia (6) monti l'OR (4) sul suo perimetro e che abbia le tre molle di compensazione (5) nelle apposite sedi;
11. Appoggiare il guscio posteriore (3) alla cartuccia (6) appena inserita;
12. Fissare le viti M5x25 (1), M5x30 (2) e portare in appoggio il guscio posteriore (3) al guscio anteriore completo di tromba (8). Verificare che in chiusura l'OR (4) perimetrale alla cartuccia (6) non fuoriesca dal guscio (3) garantendo così la tenuta.

PROBLEMI E SOLUZIONI

I

Nel caso di mancato funzionamento del sistema procedere come segue :

1. Verificare la continuità del fusibile ed eventualmente sostituirlo.
2. Piccoli corpi solidi come ad esempio limatura di metallo possono causare lo stesso inconveniente. In tal caso procedere alla pulizia come detto precedentemente.

MANUTENZIONE ORDINARIA

I-1

Controllare mensilmente che i cavi di alimentazione elettrica siano in buone condizioni;
Sostituire ogni 1000 ore di funzionamento la calotta del compressore.

INDICATORI DEL CORRETTO FUNZIONAMENTO DEL DISPOSITIVO

I-2

- Temperatura della carcassa del motore contenuta tra 60°C - 70°C.
- Emissione sonora costante.

APERTURA DEL DISPOSITIVO

I-3

Si consiglia di far intervenire del personale specializzato per effettuare riparazioni o sostituzioni di materiale d'usura all'interno del dispositivo, esclusivamente con ricambi originali;

Nel periodo di garanzia solo personale autorizzato di Marco S.p.A., pena decadimento della stessa.

SMALTIMENTO

L

Non gettare le trombe dismesse tra i rifiuti domestici: esse debbono essere raccolte separatamente ed inviate ad una riutilizzazione ecologica.

GARANZIA

M

1. Il periodo di garanzia è di 2 anni dalla data d'acquisto come risulta dalla relativa fattura.
2. Nel caso la fattura non fosse disponibile il periodo di garanzia di 2 anni, sarà calcolato dalla data di fabbricazione.
3. La garanzia decade e s'intende nulla in caso d'utilizzazione non corretta o nel caso venissero ignorate le istruzioni contenute nel presente manuale.
4. La garanzia copre solamente i difetti di fabbricazione.
5. La garanzia non copre i costi connessi di installazione e smontaggio.
6. I costi di trasporto sono rimborsabili solo nel caso in cui la garanzia è stata debitamente riconosciuta e accettata da Marco S.p.A. Questi costi saranno limitati ai costi di spedizione tra il magazzino di Marco S.p.A. e la sede del cliente.
7. Nessuna nota di credito o reso sarà emessa prima di un test eseguito dal controllo di qualità di Marco S.p.A. che dichiari difettoso il prodotto.

A PRODUCT DESCRIPTION

Approved signalling whistle complete with horn \varnothing 200 mm, with electric compressor and mounting accessories. Meets COLREG 1972 IMO class IV regulations.

Approvals: RINA, LLOYD'S REGISTER MCA and BUREAU VERITAS, NMMA ABYC A-23.

B TECHNICAL DETAILS

PART NUMBER	TYPE	VOLT	FUSE	dB (1/3 OCT.)(1m)	Hz	WEIGHT	P.CS x CART.
150 002 12	PW2-BC	12	25 A	>120	315	4,9 kg	1
150 002 13		24	20 A				
150 003 12	PW2-BB	12	25 A				
150 003 13		24	20 A				
150 006 12	PW2 -BN	12	25 A				
150 003 13		24	20 A				

C AMBIENT CONDITIONS

Temperature: min. -25 °C / max. +60 °C **Relative humidity:** max. 90 %

Store the product in a dry area.

D ELECTRICAL CONNECTIONS

The electric product must be connected to a source of direct current (either battery or DC power supply). The product must be protected by a suitable rated fuse

E OPERATING CYCLE

The product has been designed for discontinuous use.

The above indicated temperature ranges are applicable to all components of the product and these limits must be respected in order to avoid any possible damage or malfunctioning.

F APPLICATIONS

Acoustic signalling horn.

G TRANSPORTATION AND HANDLING

Due to limited weight and dimensions the product does not require the use of any special handling or lifting equipment. When handling manually, normal personal protective gear should be worn (safety shoes with toe piece, etc.)

The product is carefully packed prior to shipment. Upon receiving, the product packaging should be inspected for damages and the product stored in a dry area.

INSTALLATION

H

It is recommended that the use of the product be according to normative safety standards and also as per the precautions listed below.

PACKAGING ENVIRONMENTAL DISPOSAL

H-1

The user is invited to effect a proper waste separation, in order to facilitate the recycling of the materials of which the packing is composed; disposal like CER 15.01.01/02

PRELIMINARY CHECKS

H-2

Check that there has been no damage to the product during transportation or storage. The outlet port should be carefully cleaned removing possible dust or residual packaging material. Verify that the available electrical power supply corresponds to the product specification requirements.

POSITIONING OF THE PRODUCT

H-3

The electric air compressor can be mounted in any position. Fix the product utilizing suitable screws corresponding to the antivibration mounts supplied with the product.

TUBING CONNECTIONS

H-4

Avoid choking the outlet tube so that product efficiency is optimized.

PRODUCT INSTALLATION

H-5

The electrical installation of the product must include a protection fuse which is suitably rated as indicated on the motor label and sized.

WARRANTY EXPIRES IF NO FUSE IS UTILIZED

Always mount the anti vibration rubber fittings supplied with the product kit. Their usage ensures a consistent reduction in noise and vibration levels.

Electrical cabling size should depend on the distance between product and battery power supply.

Section of cables:

For connections to the battery up to 5 meters: 4,0 mm² per 12V - 2,5 mm² per 24V

The use of undersized cabling can cause overheating of the electrical wiring and subsequent fire hazard. There will also be a voltage drop at the motor terminals with a consequent reduction in efficiency.

The flow rate value indicated on the motor label is obtained with a 6 mm internal tube diameter. Tubes with inferior diameters will cause an increase in current with potential risk of motor overheating.

WARNING: it is the responsibility of the installation technician to ensure a correctly designed circuit installation fitted according to regulations. Environmental risks must be taken into account with the installation.

1. **Install the horn angled slightly downward (5°) in order to avoid the water stagnation within the cone.**
2. Connect the loudspeaker to the compressor through the Rilsan pipe using the accessories in the kit, see the layout attached.
3. Fix the compressor to a flat surface using M5 screws. Use the rubber vibration-damping in order to avoid any vibrations during the execution.
4. Connect in series the service switch to the red cable.
5. Connect the extreme part of the red cable to the positive pole of the battery (+) and the extreme part of the black cable to the negative pole of the battery (-).

H-6

WHISTLE MOUNTING SEQUENCE

1. Drill the supporting surface of the horn (14) using the rubber mat (11) as template;
2. Unscrew the M5X25 (1) and M5x30 (2) screws ;
3. Remove the back cover (3);
4. Remove the spring (5);
5. Slip off carefully the cartridge (6) with a screwdriver at the point "C" (Tab.1);
6. Put the rubber mat (11) just next to the fixing holes previously made;
7. Put the horn housing complete with trumpet (8) on the rubber mat (11);
8. Fix the horn housing complete with trumpet (8) on the supporting surface (14) by two M5 screws (9) and elastic washers (10) and lock it through the self-locking nut (13) and washers (12);
9. Insert from below the rilsan tubing into the specially provided hole (A) and insert into the quick-fit connection (A);
10. Insert carefully the cartridge (6) into the horn housing complete with trumpet (8) centring it on the trumpet tube end. Make sure that the trumpet tube is complete with the O-ring (7) and that the cartridge (6) has the O-ring (4) on the outer edge and that the three compensation springs (5) are located in the specially provided seats.
11. Place the back cover (3) on the inserted cartridge (6).
12. Insert the M5x25 (1), and M5x30 (2) screws into the specially provided seats and screw them until the back cover (3) rests on the horn housing complete with trumpet (8). Make sure that the O-ring (4) of the outer edge of the cartridge (6) does not protrude from the back cover (3) ensuring therefore a perfect tightness.

TROUBLESHOOTING

I

In the case of a system malfunction proceed as follows :

1. Check the continuity of the fuse and eventually change it.
2. Small solid bodies such as metal filings can cause the same problem . In this case clean the membranes as said above.

NORMAL MAINTENANCE

I-1

Check every month that electrical wiring is in good condition;
Every 1000 hours of pump operation substitute the motor brushes.

INDICATORS THAT THE PRODUCT IS FUNCTIONING CORRECTLY

I-2

- Temperature of motor frame within 60°C - 70°C;
- Regular sound emission level;

TO OPEN THE PRODUCT

I-3

It is recommended that a specialized service technician be consulted for any pump repair work or the replacement of worn out internal components, exclusively with original spare parts;

During the warranty period, only by authorized Marco S.p.A. personnel, failing which the warranty will expire.

ENVIRONMENTAL DISPOSAL

L

Do not dispose of horns into household waste. Horns that are non longer usable must be collected separately and disposed of in an environmentally correct manner.

WARRANTY

M

1. The Warranty period is 2 years from date of purchase on production of the appropriate sales invoice.
2. Should the original sales invoice not be available, then the 2 year warranty period will be valid from production date.
3. The Warranty becomes null and void in the case of incorrect utilization or disregard of the instructions contained herein.
4. The Warranty only covers original production defects.
5. The Warranty does not cover any related installation costs involved.
6. Transport costs are refundable only in the case where warranty has been duly recognized and accepted by Marco Spa. These costs will be limited to the actual shipment costs between Marco Spa warehouse and the client's delivery address.
7. No credit notes or replacement items will be issued prior to the receipt and proper testing of any Marco goods that are deemed faulty.

N SCHEMA DI COLLEGAMENTO / CONNECTING LAYOUT

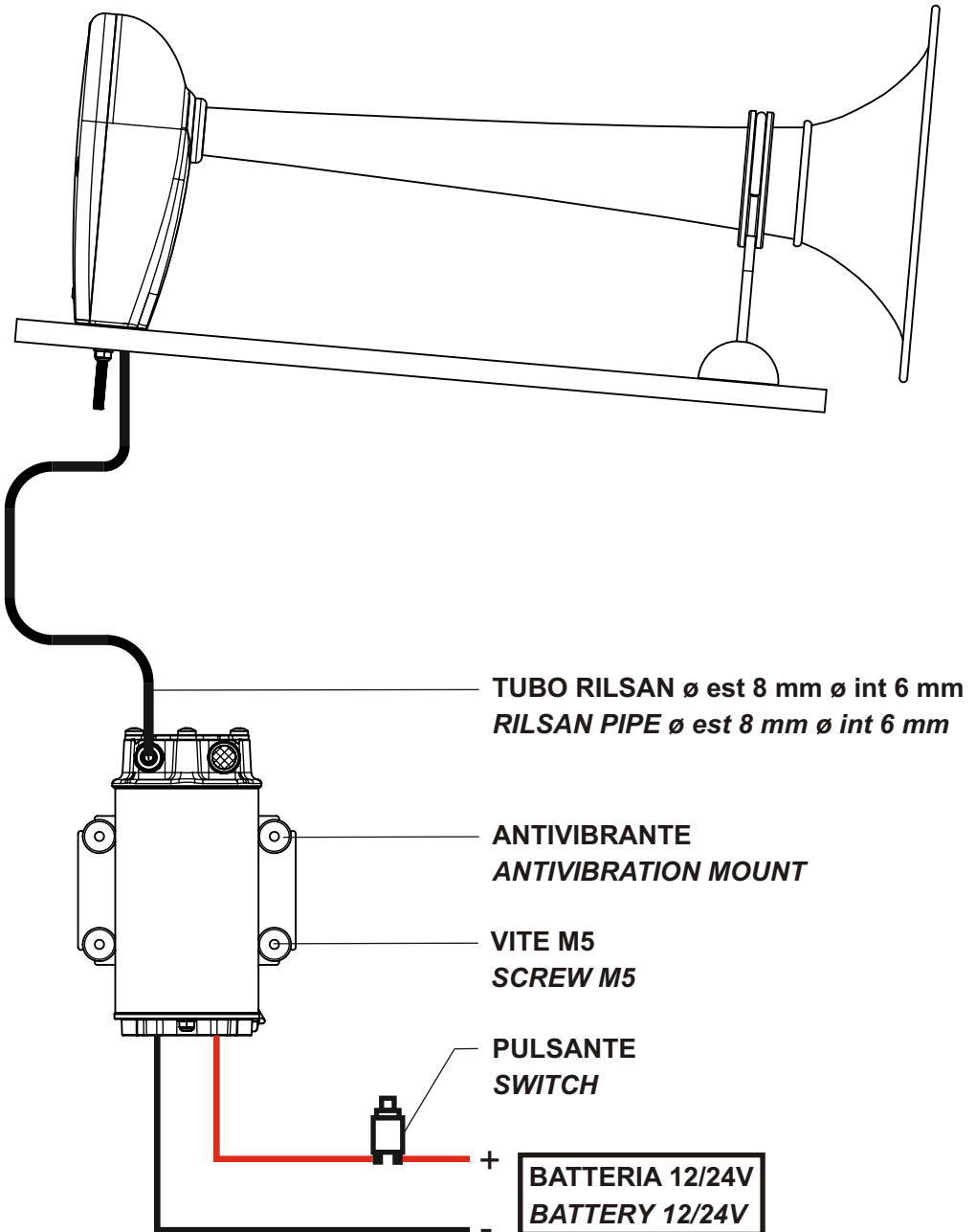

SCHEMA DI MONTAGGIO / MOUNTING LAYOUT

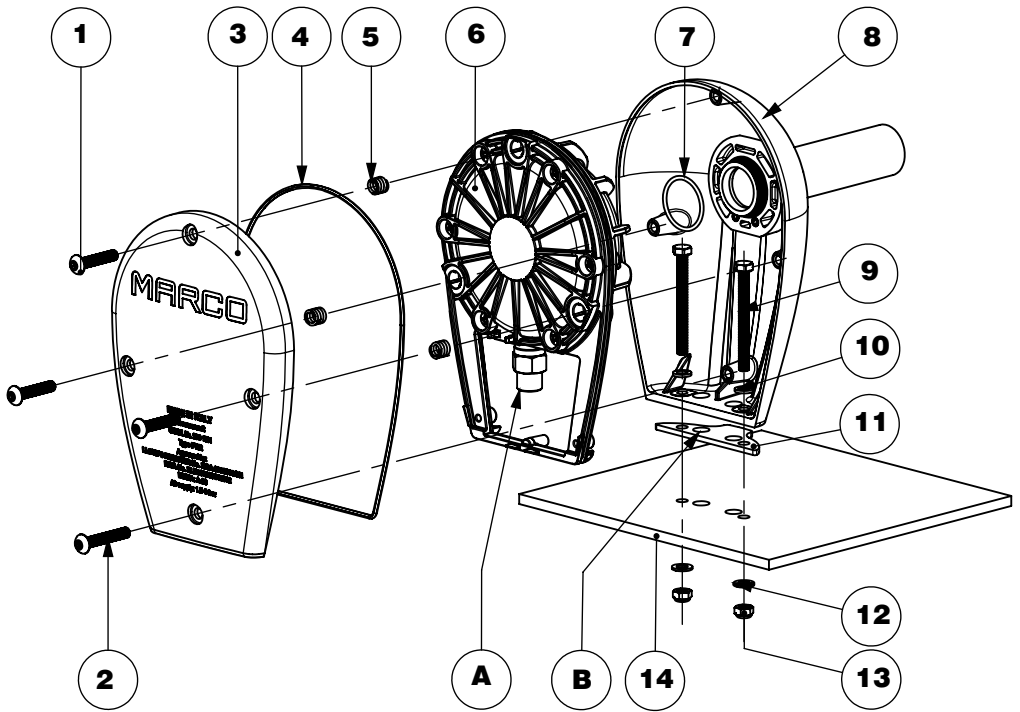

Tab.1

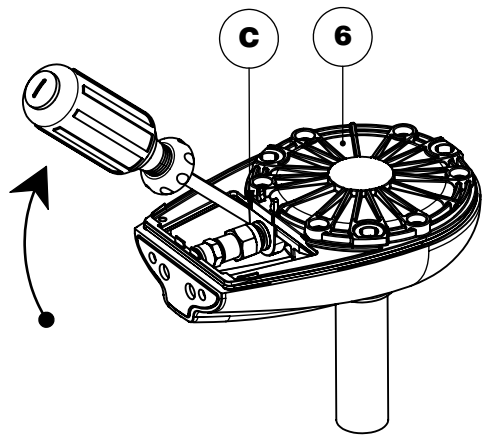

01 **SCHEDA DI ASSEMBLAGGIO / EXPLODED VIEW**

Pos.	Q.tà	Descrizione
1	1	CORNETTO
2	1	GUSCIO FRONTALE
3	1	O-RING
4	1	CARTUCCIA
5	3	MOLLA
6	1	O-RING
7	1	GUSCIO POSTERIORE
8	3	VITE
9	1	VITE
10	1	RACCORDO RAPIDO
11	2	RONDELLA

Pos.	Q.tà	Descrizione
12	2	VITE
13	1	TAPPETO
14	2	RONDELLA
15	2	DADO
16	1	ANELLO
17	1	O-RING
18	1	GANCIO
19	2	VITE
20	1	GRANO
21	1	SOSTEGNO
22	1	O-RING

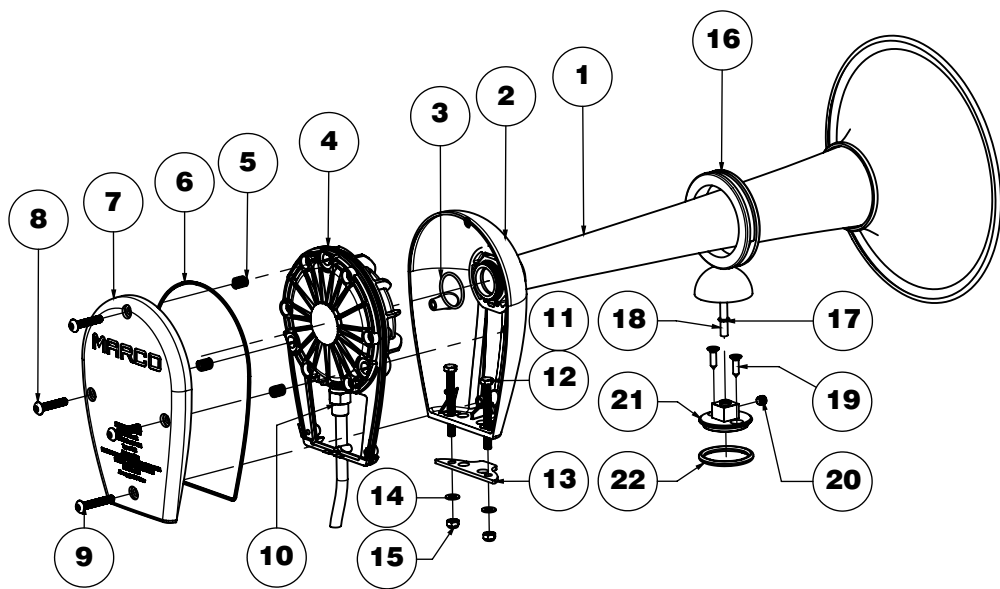

Pos.	Q.ty	Description
1	1	TRUMPET
2	1	FRONT LID
3	1	O-RING
4	1	CARTDRIGE
5	3	SPRING
6	1	O-RING
7	1	BACK LID
8	3	VITE
9	1	SCREW
10	1	QUICK FIT
11	2	WASHER

Pos.	Q.ty	Description
12	2	SCREW
13	1	CARPET
14	2	WASHER
15	2	NUT
16	1	RING
17	1	O-RING
18	1	HOOK
19	2	SCREW
20	1	HEADLESS SCREW
21	1	SUPPORT
22	1	O-RING

INGOMBRI / DIMENSIONS

P

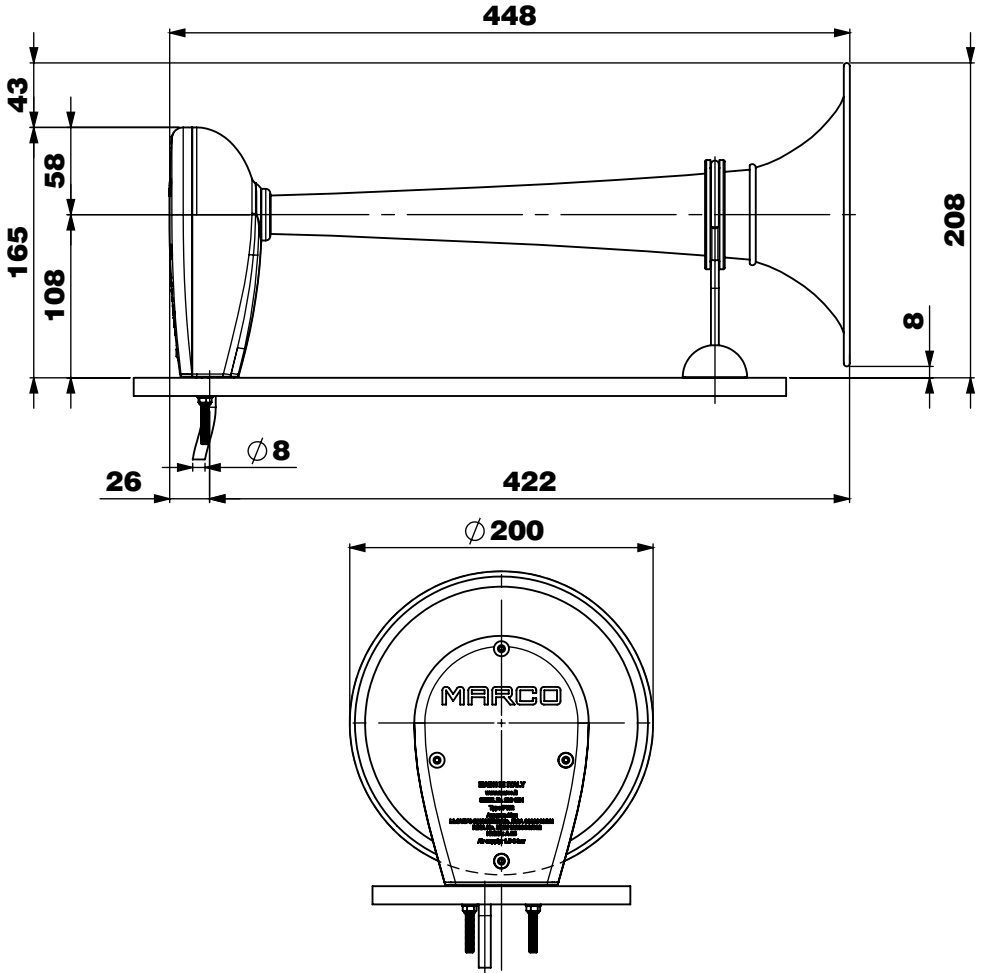

TAPPETO IN GOMMA / RUBBER CARPET

P1

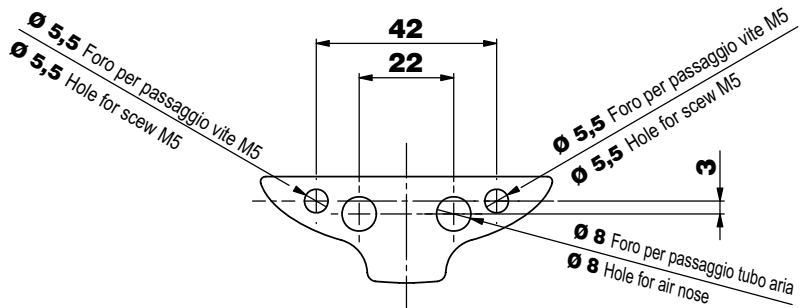

INGOMBRI / DIMENSIONS

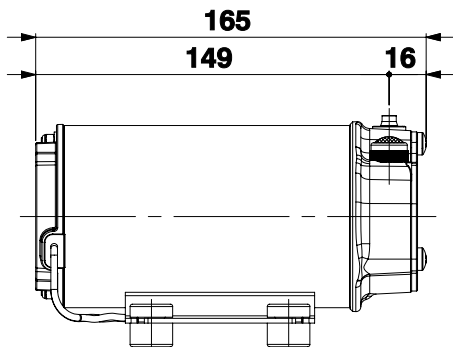
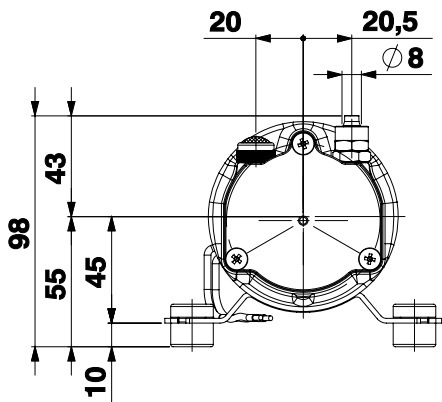
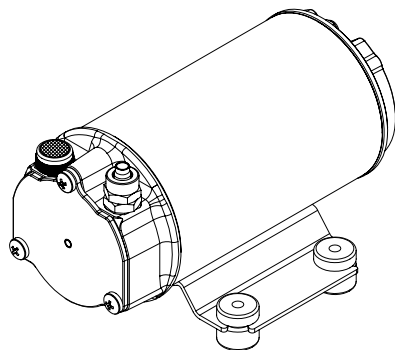
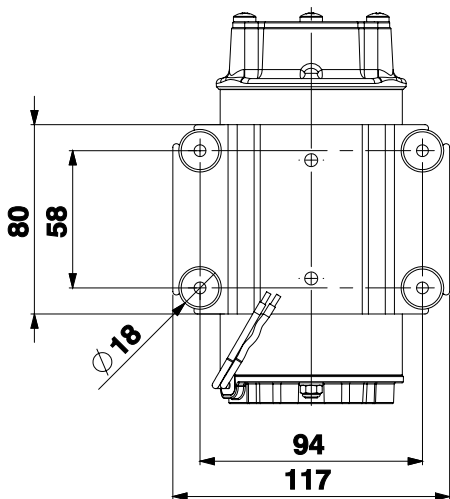

ANTIVIBRATION MOUNT

1	2	3
* VITI NON INCLUSE / SCREWS NOT INCLUDED		

PROTOTYPE DESIGN ASSESSMENT CERTIFICATENo. **ELE333323CS****Enclosure - Page 1 of 1****PW2 and PW3****Whistle Type PW2**

Field of application (acc.to COLREG Regulation)

Vessels having lenght L<20 meters

Sound pressure level 1/3 octave band @ 1m: 120 dB

Audibility: 0,5 mile

Feeder

Compressed air

Air pressure supply: from 0,15 to 0,30 MPa

Whistle Type PW3

Field of application (acc.to COLREG Regulation)

Vessels having lenght L<20<75 meters

Sound pressure level 1/3 octave band @ 1m: 130 dB

Audibility: 1 mile

Feeder

Compressed air

Air pressure supply: from 0,60 to 1,20 MPa

Test Report and drawing:

RINA Report n.2013/CS/01/534 (19/07/2013): frequency and sound pressure measurements (19/07/2013)

MARCO Letter on 06/02/2008

SQS Certificate dated 14.06.2021

Drawing no. 5.413 stamped by RINA on 13/04/1988

Reference documents:

Offer n° 2023/22330 (dated 11/09/2023)

TAC APP dated 31/08/2023

<https://leodrawplus.rina.org/projects/40216/detail>**Genova October 30, 2023**

RINA Services S.p.A.
Via Corsica, 12 - 16128 Genova
Tel +39 010 53851
Fax +39 010 5351000

Digitally signed by RINA Services S.p.A. on 30 Oct 2023. No handwritten signature is provided.



PROTOTYPE DESIGN ASSESSMENT CERTIFICATE
No. ELE333323CS

This is to certify that the product identified below is in compliance with the regulations herewith specified.

<i>Description</i>	SHIP'S WHISTLE
<i>Type</i>	PW2 and PW3
<i>Applicant</i>	MARCO SPA VIA MAMELI, 10 25014 CASTENEDOLO (BS) ITALY
<i>Manufacturer</i>	MARCO SPA
<i>Place of manufacture</i>	VIA MAMELI, 10 25014 CASTENEDOLO (BS) ITALY
<i>Reference standards</i>	Convention on the International Regulations for preventing collisions at sea, 1972 (ref. to Italian Law 27th December 1977 no. 1085.)

This certificate is issued on request of the Manufacturer based on the PDA certification scheme according to RINA Rules for Testing and Certification of Marine Materials and Equipment

Issued in **Genova** on **October 30, 2023**. This Certificate is valid until **October 29, 2028**

RINA Services S.p.A.
Luigi Benedetti

This certificate consists of this page and 1 enclosure

RINA Services S.p.A.
Via Corsica, 12 - 16128 Genova
Tel +39 010 53851
Fax +39 010 5351000

Digitally signed by RINA Services S.p.A. on 30 Oct 2023. No handwritten signature is provided.



This certificate is issued under the authority given in Merchant Shipping Notice No MSN 1674 (M+F) Annex 2 as amended to date.

Page 1 of 3
 Certificate No: LR21191508MC
 Issue Date: 11 Mar 2021
 Expiry Date: 10 Mar 2026



Certificate Of Type Approval (MCA)

This is to certify that LLOYD'S REGISTER, specified as a "person" under the terms of The Merchant Shipping (Marine Equipment) Regulations 2016 (SI2016 No. 1025), did undertake the relevant type approval procedures of the equipment identified below which was found to be in compliance with the International Regulations for preventing Collisions at Sea, 1972 (COLREG 72), as amended, requirements subject to any conditions in the Design Appraisal Document hereto.

Manufacturer	Marco S.p.A.
Address	Via Mameli 10, 25014 Castenedolo, Brescia, Italy
Type	SHIPS SOUND SIGNAL (WHISTLE) AIR OPERATED
Description	SHIPS SOUND SIGNAL (WHISTLE) AIR OPERATED
Trade Name	PW2
Specified Standard	International Regulations for Preventing Collisions at Sea 1972, Consolidated Edition 2002, Annex III, 1(a) to (d) inclusive. EN 60945 (2002)

This certificate is not valid for equipment, the design or manufacture of which has been varied or modified from the specimen tested. The manufacturer should notify Lloyd's Register EMEA of any modification or changes to the equipment in order to obtain a valid Certificate.

The attached Design Appraisal Document forms part of this certificate.

This certificate remains valid up to the expiry date, unless cancelled or revoked, or until such date where it is superseded by the requirements of the Marine Equipment Directive, whichever is sooner, provided the conditions in the attached schedule are complied with and the equipment remains satisfactory in service.

Lijo Thomas
 Senior Surveyor to Lloyd's Register EMEA
 A member of the Lloyd's Register group

71 Fenchurch Street, London, EC3M 4RS, United Kingdom

Lloyd's Register Group Limited, its affiliates and subsidiaries and their respective officers, employees or agents are, individually and collectively, referred to in this clause as 'Lloyd's Register'. Lloyd's Register assumes no responsibility and shall not be liable to any person for any loss, damage or expense caused by reliance on the information or advice in this document or howsoever provided, unless that person has signed a contract with the relevant Lloyd's Register entity for the provision of this information or advice and in that case any responsibility or liability is exclusively on the terms and conditions set out in that contract.

TA17 1.0.0



DESIGN APPRAISAL DOCUMENT

Page	2 of 3
Certificate No:	LR21191508MC
Issue Date:	11 Mar 2021
Expiry Date:	10 Mar 2026
Reference:	UKITSO/LSA/TA/LT/WP43048498/PRJ11100305257

ATTACHMENT TO CERTIFICATE OF TYPE APPROVAL No. LR21191508MC

The undernoted documents have been appraised for compliance with the relevant International Conventions and UK legislation for the Type Approval of Marine Equipment for use on Merchant Ships Registered in the United Kingdom.

This Design Appraisal Document forms part of the Certificate that is issued under the authority given in the MCA Merchant Shipping Notice No MSN 1874.

This Certificate is a renewal of Certificate No. MCA 1600003

EXAMINED DOCUMENTS

LR Brescia email	11.03.2008
Marco letter	10.03.2008
PW2 Data Sheet, Rev 07 (Trumpet)	22.07.2014

TEST REPORTS

IQNet Certificate No. CH-21294	07.02.2006
SQS Certificate No. 21294	07.02.2006
Environmental and Vibration Test, Test Report No: AERO15_016 , Rev 0	15.09.2015
Sound Pressure Test after Environmental and Vibration test, Rev 0	18.12.2015

CONDITIONS OF CERTIFICATION

1. The PW2 whistles may only be fitted to vessels greater than 12 meters but less than 20 metres in length
2. The onboard arrangements and installation of this whistle is not part of this certificate, all such arrangements are to be to the satisfaction of the attending surveyor
3. Each whistle is to be delivered with a copy of this certificate
4. Instructions for use and maintenance are to be supplied with each whistle
5. If the specified standards are amended during the validity of this certificate, this product type is to be re-approved prior to it being supplied to vessels to which the amended standards apply
6. Production items are to be manufactured in accordance with a quality control system which shall be maintained to ensure compliance with SOLAS Regulation III/5
7. Production tests are to be conducted in accordance with the applicable requirements of IMO Resolution MSC.81 (70), Part 2 and each item, batch, or lot be delivered with an LR Certificate of SOLAS Production Testing issued by the attending LR Surveyors following their witness of the tests. This does not preclude any further testing to additional requirements of the Marine Administration of the country where the ship is registered (i.e. the flag state) or those acting on behalf of that Administration
8. Should a change of Place of Production from that stated below be required i.e. where the stages of manufacture/assembly/testing of this product take place, the new Place of Production is to be advised to us prior to the change taking place. This Certificate will require to be updated for Approval to be maintained

Lloyd's Register Group Limited, its affiliates and subsidiaries and their respective officers, employees or agents are, individually and collectively, referred to in this clause as 'Lloyd's Register'. Lloyd's Register assumes no responsibility and shall not be liable to any person for any loss, damage or expense caused by reliance on the information or advice in this document or howsoever provided, unless that person has signed a contract with the relevant Lloyd's Register entity for the provision of this information or advice and in that case any responsibility or liability is exclusively on the terms and conditions set out in that contract.



DESIGN APPRAISAL DOCUMENT

Page
Certificate No:
Issue Date:
Expiry Date:
Reference:

3 of 3
LR21191508MC
11 Mar 2021
10 Mar 2026

UKITSO/LSA/TA/LT/WP43048498/PRJ11100305257

ATTACHMENT TO CERTIFICATE OF TYPE APPROVAL No. LR21191508MC

PLACE OF PRODUCTION

Marco SpA
Via Mameli 10
25014 Castenedolo
Brescia
Italy

Lijo Thomas
Senior Specialist
Fire & Safety, Statutory Discipline Team
UK&I Technical Support Office, Marine & Offshore
Lloyd's Register EMEA



Lloyd's Register Group Limited, its affiliates and subsidiaries and their respective officers, employees or agents are, individually and collectively, referred to in this clause as 'Lloyd's Register'. Lloyd's Register assumes no responsibility and shall not be liable to any person for any loss, damage or expense caused by reliance on the information or advice in this document or howsoever provided, unless that person has signed a contract with the relevant Lloyd's Register entity for the provision of this information or advice and in that case any responsibility or liability is exclusively on the terms and conditions set out in that contract.



Marine & Offshore

Certificate number: 14450/D0 BV

File number: NAV 39/1469/02

Product code: 4005H

This certificate is not valid when presented without the full attached schedule composed of 7 sections

www.veristar.com

TYPE APPROVAL CERTIFICATE

This certificate is issued to

MARCO SpA

Castenedolo (BS) - ITALY

for the type of product

SHIP's SOUND SIGNALS (WHISTLES)

Air whistle type: PW2/PW3

Requirements:

Bureau Veritas Rules for the Classification of Steel Ships.

This certificate is issued to attest that Bureau Veritas Marine & Offshore did undertake the relevant approval procedures for the product identified above which was found to comply with the relevant requirements mentioned above.

This certificate will expire on: 04 Sep 2025

For Bureau Veritas Marine & Offshore,

At BV GENOA, on 04 Sep 2020,

Sandro BRUSEGAN



This certificate remains valid until the date stated above, unless cancelled or revoked, provided the conditions indicated in the subsequent page(s) are complied with and the product remains satisfactory in service. This certificate will not be valid if the applicant makes any changes or modifications to the approved product, which have not been notified to, and agreed in writing with Bureau Veritas Marine & Offshore. Should the specified regulations or standards be amended during the validity of this certificate, the product(s) is/are to be re-approved prior to it/they being placed on board vessels to which the amended regulations or standards apply. This certificate is issued within the scope of the General Conditions of Bureau Veritas Marine & Offshore available on the internet site www.veristar.com. Any Person not a party to the contract pursuant to which this document is delivered may not assert a claim against Bureau Veritas Marine & Offshore for any liability arising out of errors or omissions which may be contained in said document, or for errors of judgement, fault or negligence committed by personnel of the Society or of its Agents in establishment or issuance of this document, and in connection with any activities for which it may provide.

The electronic version is available at: <http://www.veristarnb.com/veristarnb/jsp/viewPublicPdfTypepc.jsp?id=taxend9af>

BV Mod. Ad.E 530 June 2017

This certificate consists of 2 page(s)

THE SCHEDULE OF APPROVAL

1. PRODUCT DESCRIPTION:

Types	Frequency	Sound pressure level (1m)	Length of vessels
Air whistle type PW2	630 Hz	123dB	< 20 m
Air whistle type PW3	630 Hz	132dB	20 ≤ L < 75 mm

2. DOCUMENTS AND DRAWINGS:

According to Manufacturer's specifications filed in NAV 39/1469/02.

3. TEST REPORTS:

3.1 - Air whistle type PW2:

Department of Trade Marine Directorate Certificate of Inspection and Tests,
EMIT Vibration test report RP 712 FIA 86,
City University London report on measurement sound output.

3.2 - Air whistle type PW3:

Department of Trade Marine Directorate Certificate of Inspection and Tests,
City University London report on measurement sound output.

4. APPLICATION / LIMITATION:

4.1 - Air whistle type PW2 to be installed on vessels < 20 m in length,

Air whistle type PW3 to be installed on vessels 20 ≤ L < 75 m in length.

4.2 - On board installation & Maintenance requirements according to the specified regulations and standard stated on the front page of the certificate.

5. PRODUCTION SURVEY REQUIREMENTS:

5.1 - The above products are to be supplied by **MARCO SpA** in compliance with the type described in this certificate.

5.2 - This type of product is within the category HBV of Bureau Veritas Rule Note NR320 and as such does not require a BV product certificate.

5.3 - **MARCO SpA** has to make the necessary arrangements to have its works recognised by Bureau Veritas in compliance with the requirements of NR320 for HBV products.

5.4 - For information, **MARCO SpA** has declared to Bureau Veritas the following production site(s):

MARCO SpA
Via Mameli 10,
25014 Castenedolo Brescia
ITALY

6. MARKING OF PRODUCT:

6.1 - Maker's name or trademark,

6.2 - Serial number of the units,

6.3 - Equipment type number or model identification under which it was type-tested.

7. OTHERS:

7.1 - It is **MARCO SpA's** responsibility to inform shipbuilders or their sub-contractors of the proper methods of fitting, use and general maintenance of the approved equipment and the conditions of this approval.

7.2 - This Certificate supersedes the Type Approval Certificate No.14450/C1 BV issued on 21 May 2015 by the Society.

*** END OF CERTIFICATE ***

BSH
Az.: 4615/6023034/16

Marco
Via Mameli 10
25014 CASTENEDOLO Brescia
Italien

Ihr Antrag auf Baumusterprüfung von Navigationsausrüstung vom 12.04.2016
Your application for type examination of navigation equipment dated 12.04.2016



BUNDESAMT FÜR
SEESCHIFFFAHRT
UND
HYDROGRAPHIE

Hamburg,
19.04.2016

Bescheid über die Anerkennung der nationalen Zulassung eines EU-Mitgliedstaates

Notification of acceptance of a national type approval of a EU member state

Sehr geehrte Damen und Herren,
Dear Madam and Sir,

für die Navigations Ausrüstung mit der Bezeichnung **PW2, PW3**
For the navigation equipment with the type designation PW2, PW3

wird die mit anliegendem Zertifikat Nr. **MCA1600002, MCA1600003**
the approval granted with attached certificate no. MCA1600002, MCA1600003

für MCA(UK) ausgesprochene Zulassung vom Bundesamt für Seeschifffahrt und Hydrographie (BSH) für die Anwendung auf Schiffen unter Deutscher Flagge akzeptiert.
Will be accepted by the Federal Maritime and Hydrographic Agency (BSH) for the use on german flag vessels.

Bedingungen

Conditions

Diese Anerkennung erlischt bei Fristablauf, Rücknahme oder Widerruf. Der Widerruf kann ausgesprochen werden, wenn die serienmäßig gefertigten nautischen Ausrüstungsgegenstände nicht mit dem zugelassenen Baumuster übereinstimmen.

This acceptance expires after lapse of time, withdrawal or revocation. A revocation may be ordered if navigational equipment manufactured in serial production is not in compliance with the type-tested prototype.

Auflagen

Obligations

Der Hersteller oder sein bevollmächtigter Vertreter hat sicherzustellen, dass alle auf Grund dieses Bescheids gefertigten nautischen Ausrüstungsgegenstände mit den geprüften Unterlagen und mit dem Baumuster übereinstimmen.

The manufacturer or his authorized representative has to ensure that navigational equipment manufactured on the basis of this acceptance, is in compliance with the approved documentation and the type-approved prototype.

Jeder serienmäßig auf Grund dieses Bescheids gefertigte Bestandteil des nautischen Ausrüstungsgegenstandes muss an gut sichtbarer Stelle und in dauerhafter Form mit der Gerätebeschriftung entsprechend der europäischen Norm EN 60945 gekennzeichnet sein und darf mit der Baumusternummer (Nummer der Baumusterprüfbescheinigung) versehen werden. Ausgenommen davon sind Bauteile, die in der unter Wasser liegenden Außenhaut des Schiffes eingebaut werden.

Every navigational equipment component which is produced in series on the basis of this acceptance must be marked permanently and visibly with the equipment identification according to the european standard EN 60945 type and may be marked with the approval number (number of the type approval certificate). This does not apply to components installed in the vessel's outside plating below the waterline.

Der Hersteller oder sein bevollmächtigter Vertreter hat den vom Bundesamt für Seeschifffahrt und Hydrographie betrauten Personen zu gestatten, durch stichprobenartige Nachprüfungen festzustellen, ob serienmäßig hergestellte Ausrüstungsgegenstände dem geprüften Baumuster entsprechen. Das Bundesamt für Seeschifffahrt und Hydrographie kann zu diesem Zweck beim Hersteller oder seinem bevollmächtigten Vertreter Proben anfordern oder entnehmen.

The manufacturer or his authorized representative has to allow to persons authorized by the Federal Maritime and Hydrographic Agency to take random samples to prove whether equipment manufactured in serial production is in compliance with the type-approved prototype. Therefore, the Federal Maritime and Hydrographic Agency may take or demand samples from the manufacturer or his authorized representative.

Es wird empfohlen, jedem ausgelieferten Ausrüstungsgegenstand eine vollständige Kopie der Anerkennung beizufügen.

It is recommended that a complete copy of the admission certificate is provided with each equipment delivery.

Hinweise

remarks

Das Bundesamt für Seeschifffahrt und Hydrographie behält sich vor, weitere Auflagen zu erteilen.

The Federal Maritime and Hydrographic Agency reserves the right to impose additional obligations.

Rechtsbehelfsbelehrung

Notice on legal remedies available

Gegen diesen Bescheid kann innerhalb eines Monats nach Bekanntgabe Widerspruch erhoben werden. Der Widerspruch ist beim Bundesamt für Seeschifffahrt und Hydrographie, Bernhard-Nocht-Str. 78, 20359 Hamburg, schriftlich oder zur Niederschrift einzulegen.¹

Objection to this document may be filed within one month after notification. The objection must be filed in writing to, or put on record at, Federal Maritime and Hydrographic Agency, Bernhard-Nocht-Str. 78, 20359 Hamburg, Germany.

Anlage(n) Baumusterprüfbescheinigung Nr. **MCA1600002, MCA1600003**
Gebührenbescheid 790056064143

Attachment(s) Type examination certificate no. **MCA1600002, MCA1600003**
Invoice 790056064143

Mit freundlichen Grüßen

Im Auftrag

Doreen Thoma

¹ Der deutsche Text ist verbindlich.
The german text is authentic.

Questo documento e' proprieta' di Marco S.p.A la riproduzione e l'uso sono vietati.

Tutti i diritti sono riservati.

Per ulteriori informazioni vedere nostro sito internet - www.marco.it

Marco S.p.A Via Mameli 10 - 25014 Castenedolo (Brescia) – Italia

tel. +39 030 2134.1 / Fax +39 030 2134.300

Property of MARCO S.p.A reproduction prohibited. All rights reserved.

For further information visit our web site - www.marco.it

Marco S.p.A Via Mameli 10 - 25014 Castenedolo (Brescia) – Italy

tel. +39 030 2134.1 / Fax +39 030 2134.300